



11/03/2008

## ALTUS 60 RTS TECHNICAL DATA MOTOR

SDEV-CLU-IMPS 61R0

SDEV- FICA 11R3

ALTUS 60 RTS Range 1

Type of head	Star Head
Nominal voltage	230 V 50 Hz
Power supply tolerances	207 - 253 V AC
Thermal time	4 minutes
Number of wires of the cable	3
Wire section	0,75 mm <sup>2</sup>
Type of limit switch unit	Electronic
Capacity of the LSU	200 turns
Repeatability	< ± 3°
System of protection	IP 44
Interface drawings	Wheel interface LT60 206801-Crown interface LT60, LT60ADF, FTS60 & LT60CSI 206802-Interface drawing star head LT60 206803-Interface drawing LT50&60 buttons 206817.
Radio frequency	433,42 MHz
Coding	Rolling code 16million of possibilities
Capacity of memory	12 different transmitters plus 3 wireless sensors
Antenna	Integrated
Range	20 m with 2 reinforced concrete walls to be passed through
R&TTE (Radio Equipment and Telecommunications Terminal Equipment Directive)	Dir 1999/5/CE
Safety Security	EN 60335 - 2 - 97
Electromagnetic compatibility	EN 301489 - 3
Radio frequency	EN 300 - 220 - 3
Application	
Principle	
Basic crown for tube Ø	63 x 1,5 mm
Temperature working range	Normal use: -10°C to +40°C      Exceptional use (20% of the life time not simultaneous): -20°C to +70°C
Noise level	According to SOMFY measures (for information only). Worse value: in load up direction during 10 seconds.

Designation	Nm	rpm	Reference	mm			tube	W	A	°C	Brake type	kg	dBA	mm	µF
	Nominal torque	Nominal speed		L1 max.	L2 (±3 mm)	L3 max.		Rated power	Rated current	Thermal tripping		Weight	Noise	Stator	Capacitor
ALTUS 60 RTS 55/17	55	17	5005453	734	717	740	670	290	1,5	130	sliding	4,18	64	85	11
ALTUS 60 RTS 70/17	70	17	5005454	734	717	740	670	350	1,9	130	sliding	4,5	66	100	14
ALTUS 60 RTS 85/17	85	17	5005455	734	717	740	670	400	2,1	140*	sliding	4,7	66	115	15
ALTUS 60 RTS 100/12	100	12	5005456	734	717	740	670	350	1,9	130	sliding	4,82	65	100	14
ALTUS 60 RTS 120/12	120	12	5005457	734	717	740	670	400	2,1	140*	sliding	5,03	65	115	15

\* Non resetable thermal protector

Reversal of the direction : by pushing the stop button of the transmitter during 5" during the factory mode

Get control : Push the UP and DOWN button of the control in order to get control of the motor after the first power on during the factory mode

Reset of the memory : 1- double cut-off with making alive from 5" to 10".

2- push briefly the programming button of a new transmitter until the motor moves UP and DOWN briefly.

Neutral	Blue
Live	Brown
Earth	Green / Yellow

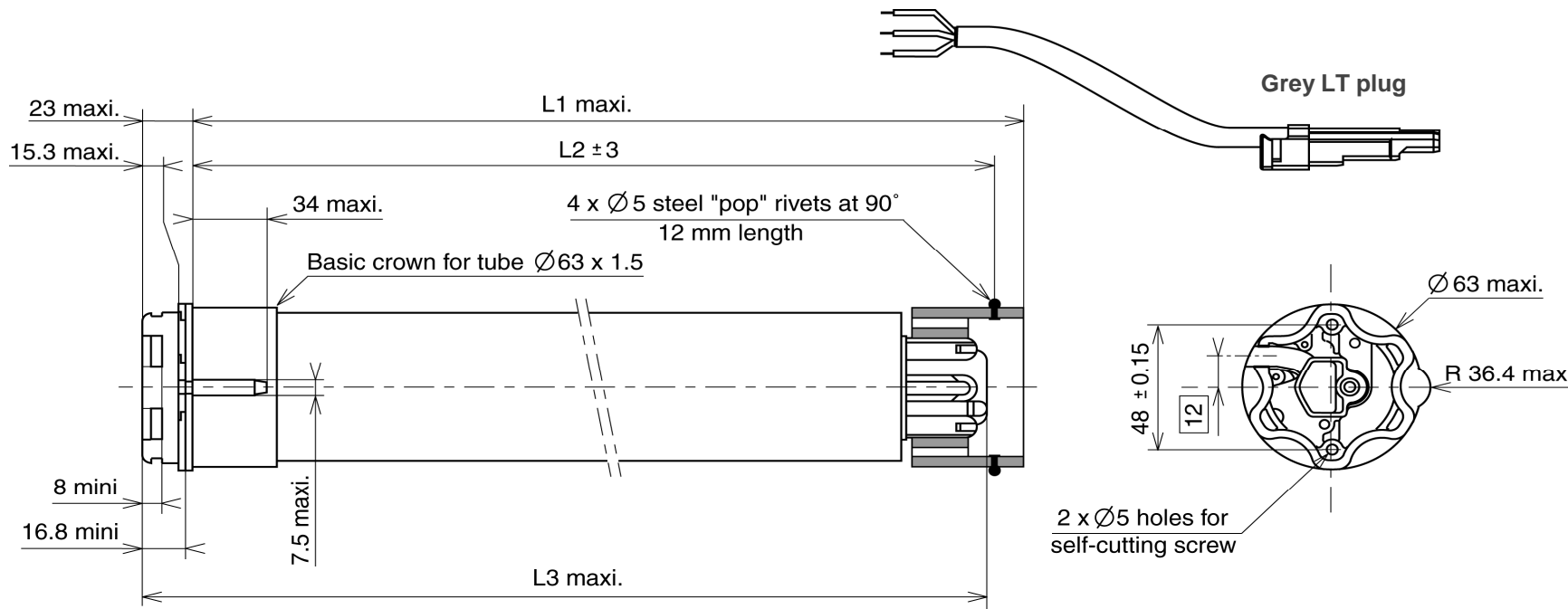

Name	R&D	QUALITY	EDITOR
Date			